

Enhancing Sewer Asset Reliability Through Innovative Stabilised No- Entry Visual Inspection Technology

James Shingles
Ozwater'26

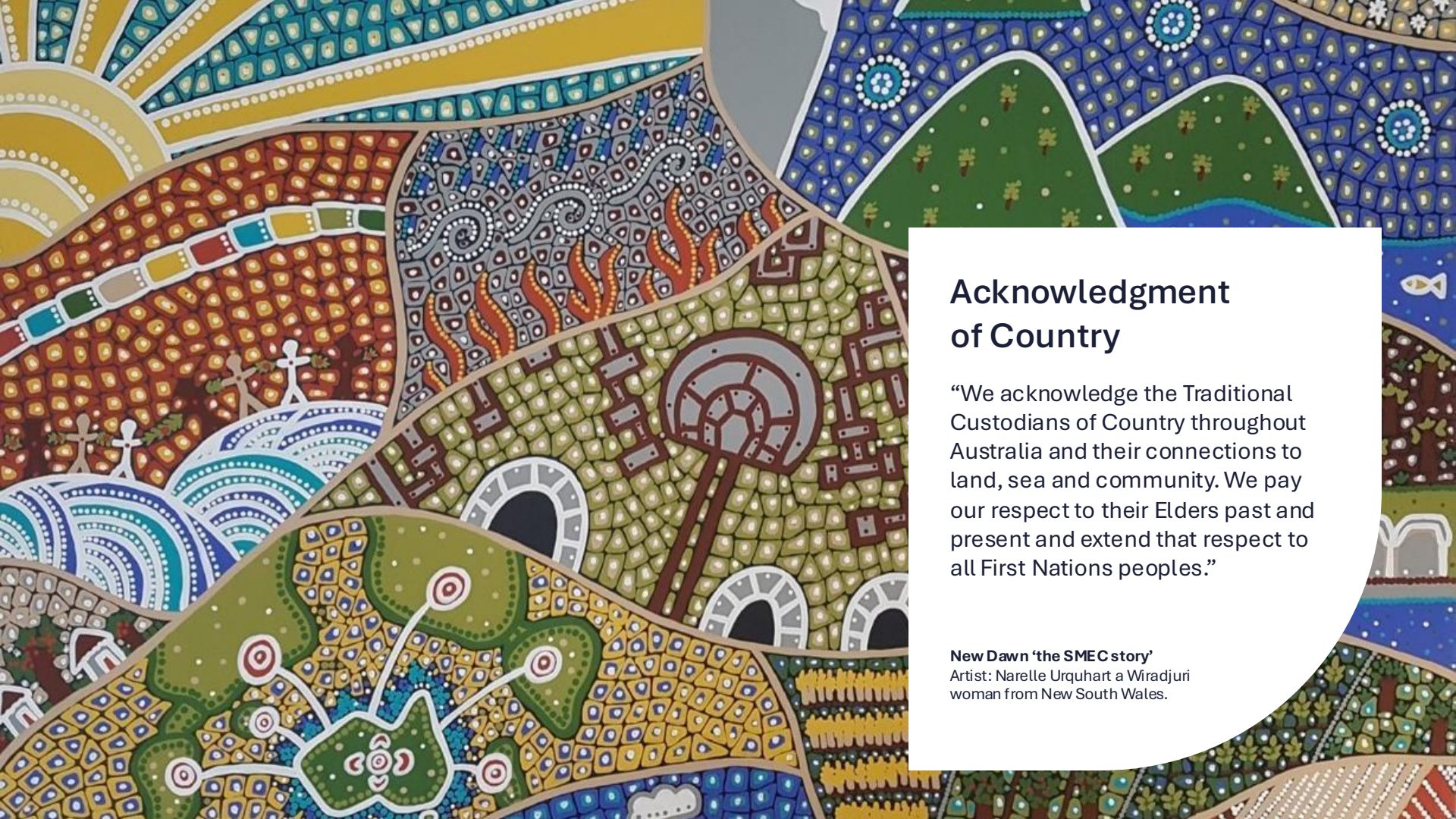



Acknowledgment of Country

“We acknowledge the Traditional Custodians of Country throughout Australia and their connections to land, sea and community. We pay our respect to their Elders past and present and extend that respect to all First Nations peoples.”

New Dawn ‘the SMEC story’

Artist: Narelle Urquhart a Wiradjuri woman from New South Wales.

SMEC simplifies the complex. We unlock the potential of our people to look at infrastructure differently, creating better outcomes for the future.



engineering
positive
change



Remote Visual Inspections



Asset management of sewer infrastructure

- Water and Sewer infrastructure plays a crucial role in modern societies.
- Planning and construction are significant investments to a city.
- Investments in asset health are just as crucial.
- Early fault identification is crucial for cost effective refurbishment.
- Delayed intervention increases cost, complexity, and health and safety.



Early intervention and rehabilitation options

Early intervention is key. It increases options for rectification

- ✓ *Lower cost*
- ✓ *Less Invasive*
- ✓ *Reduced Planning and Complexity*
- ✓ *Reduced Shut Times*



Epoxy Pipe Lining



Manhole Well Washer



Shotcrete Pipeline Repair

Traditional technique: manned entry visual inspection

Manned Visual Inspection:

- Confined space entry
- H₂S gas monitoring
- Health and safety risk
- High planning associated
- Inspection by the operator's eye only
- Flow control plan



Solution: remote visual inspection

- Original design for manhole inspections
- Visual inspection mitigating health and safety risks of manned entry
- Simplistic design – Rope and pulley
- Fast deployment
- Cost-effective construction
- Stability and lighting issues

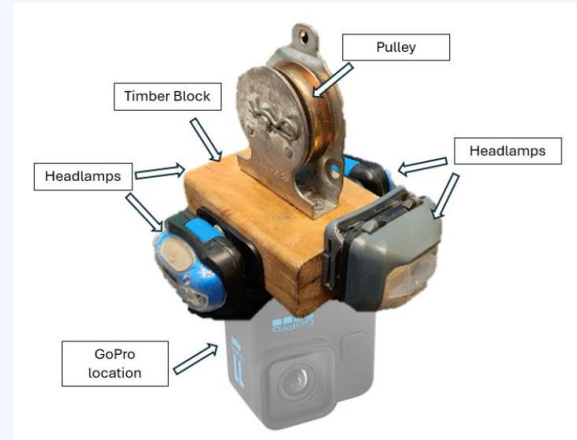
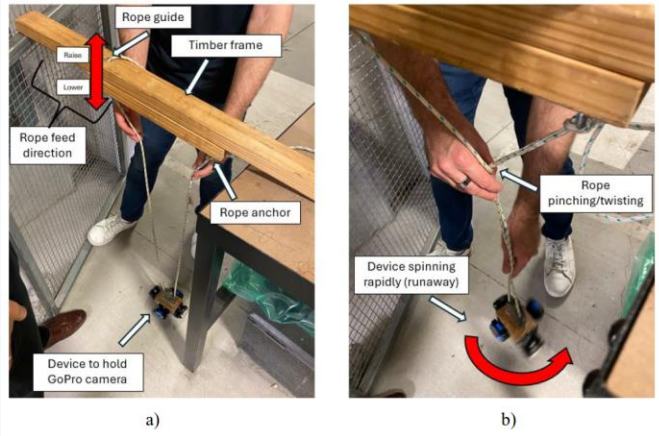

Original device: lighting and stability issues

Stability:

- Rope and Pulley design
- Shakey footage at lower depths
- Uncontrolled spinning – Runaway effect

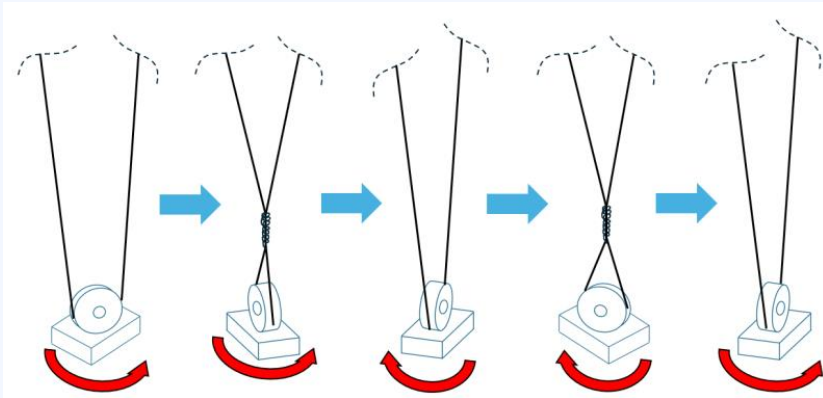

Original Device Runaway Effect

Lighting

- 4 x headlamps
- High intensity spotlights
- Under exposed areas

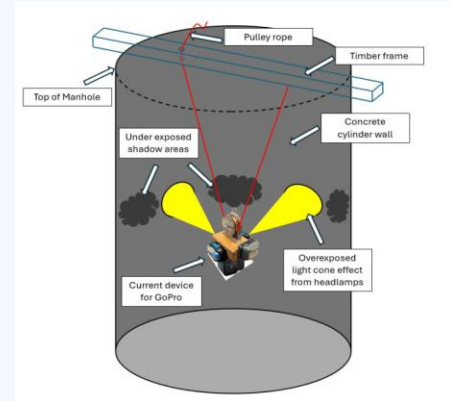

Original Device Spotlighting

Functional criteria for development

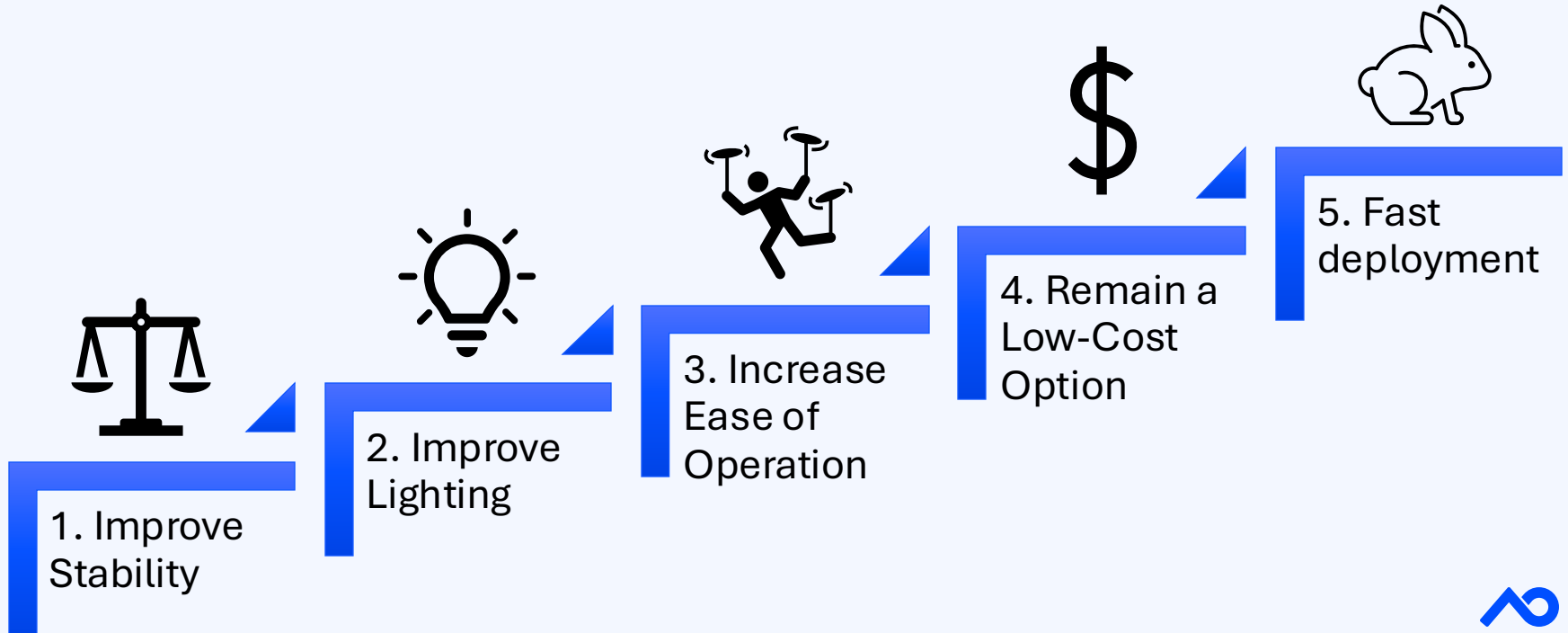

Design & Testing

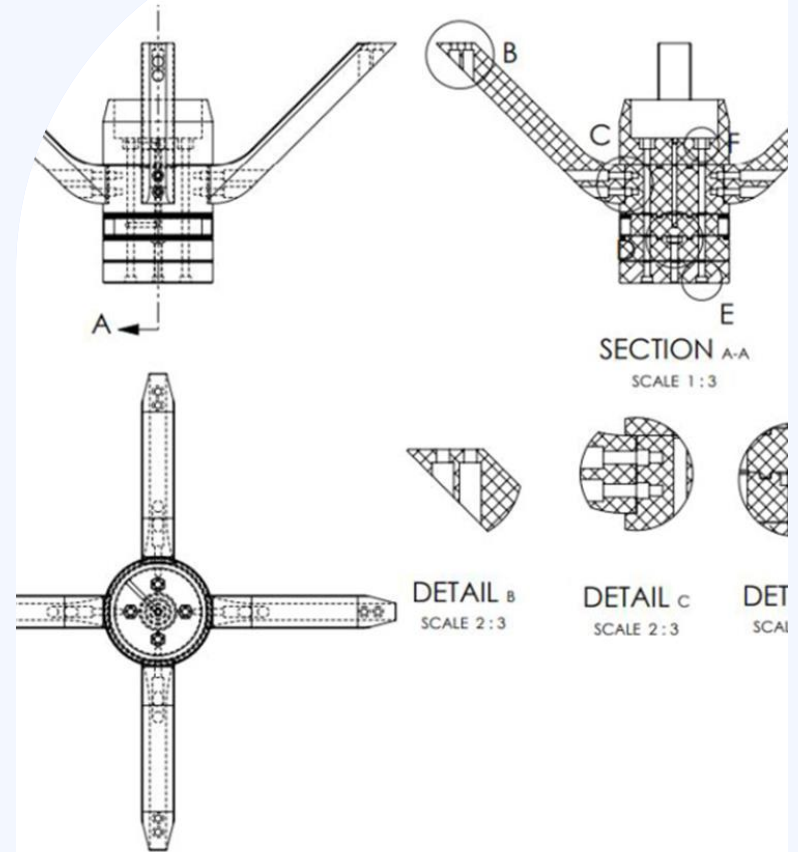

Design overview

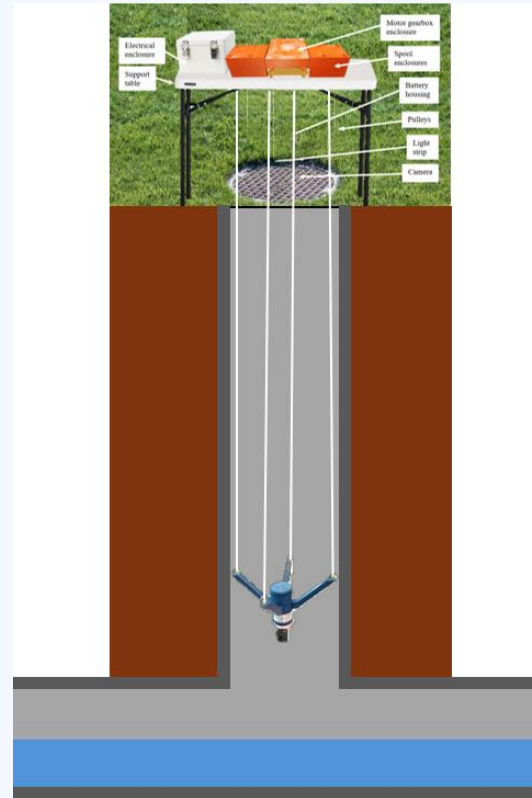
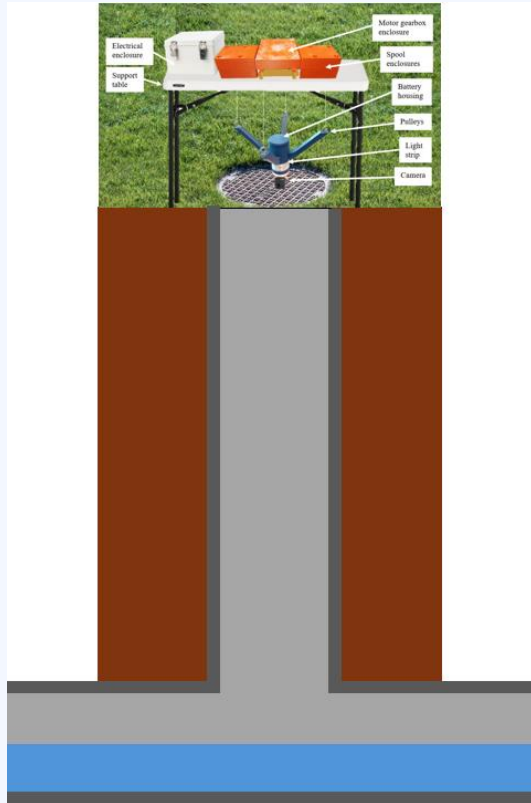

Design Overview

Functions:

- 4 x Pulley Design
- LED Lighting Strip
- Motor Gearbox Spool Remote Operation

Components:

- Lower assembly
- Gearbox Motor Spool housing
- Electrical Housing
- Remote Control
- Table Support



Design Overview



MARA Device Demonstration

Upper Assembly:



Spool and Housing

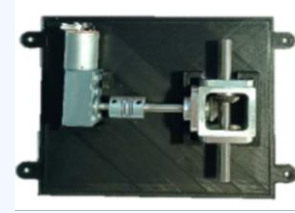

Motor and Gearbox



Remote control Operation

Lower Assembly:

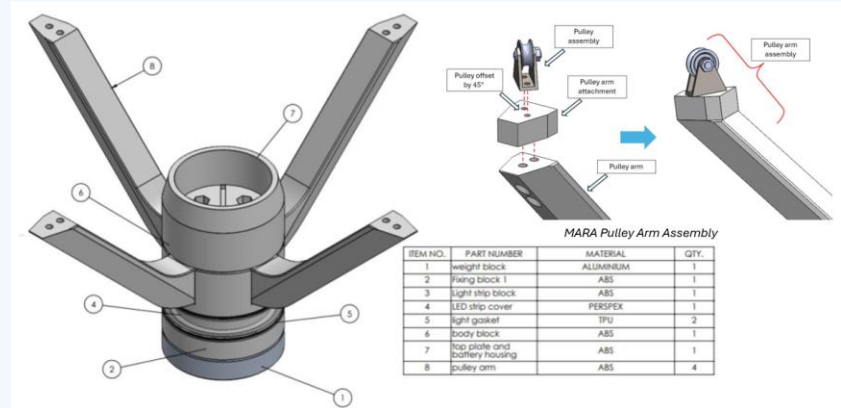

Deployed Camera Mounted Device



Functional Testing: **Stability** – Methodology

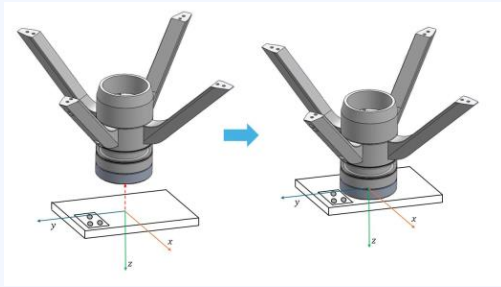
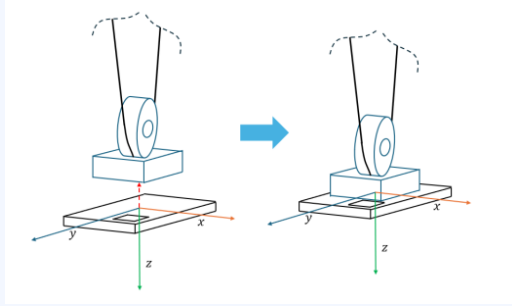

Sensor mounting for stability testing on previous device (Top) and MARA device (Bottom)

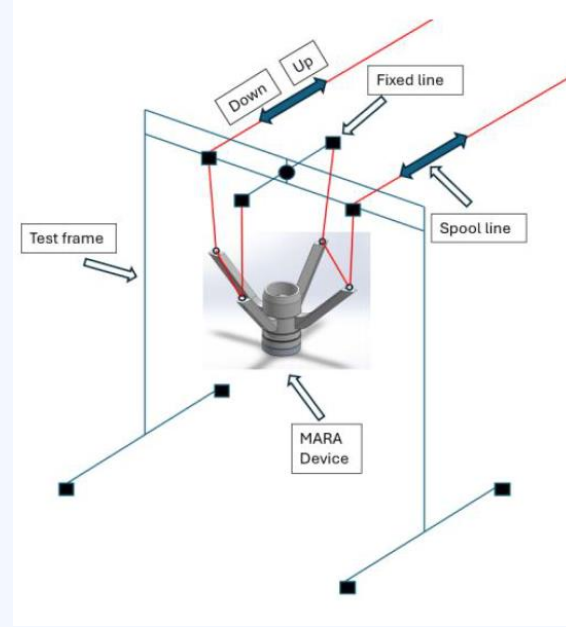

Schematic of testing rig used to lower device for stability testing



Functional Testing: **Stability** – Results

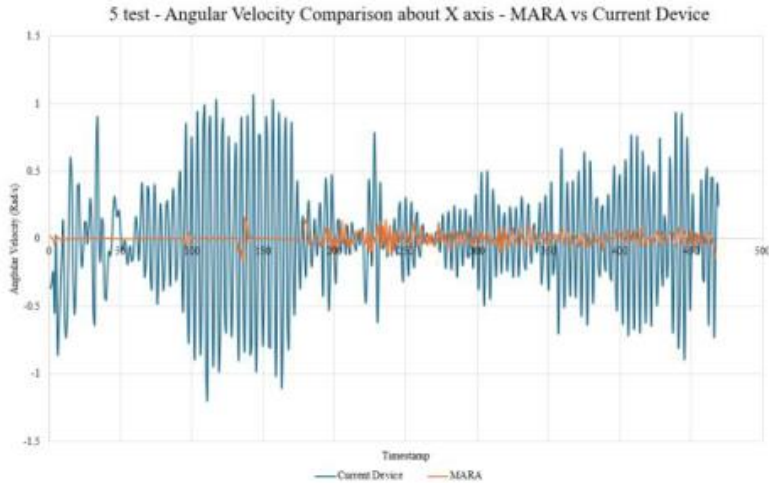

a)

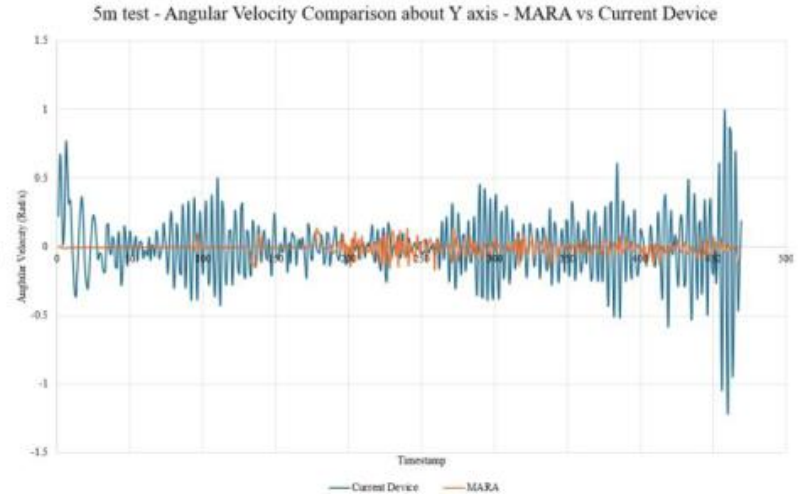

b)

Functional Testing: **Stability** – Results

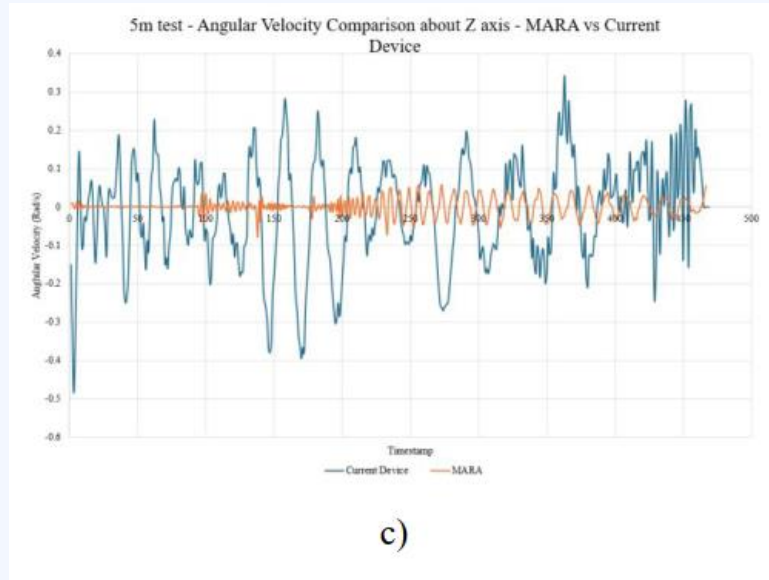

RESULTS OF 5M ORIENTATION TEST COMPARING ORIGINAL DEVICE TO MARA

Axis	Device	Range	Variance	RMSE
X	MARA	0.33	0.0019	0.07
	Current	2.24	0.17	0.71
	Difference (%)	85.08	98.88	89.59
Y	MARA	0.30	0.0020	0.08
	Current	2.51	0.07	0.46
	Difference (%)	87.90	97.17	83.20
Z	MARA	0.14	0.0005	0.04
	Current	1.72	0.04	0.34
	Difference (%)	92.15	98.71	88.80
Average difference (%)		88.38	98.25	87.20

Functional Testing: Lighting – Methodology

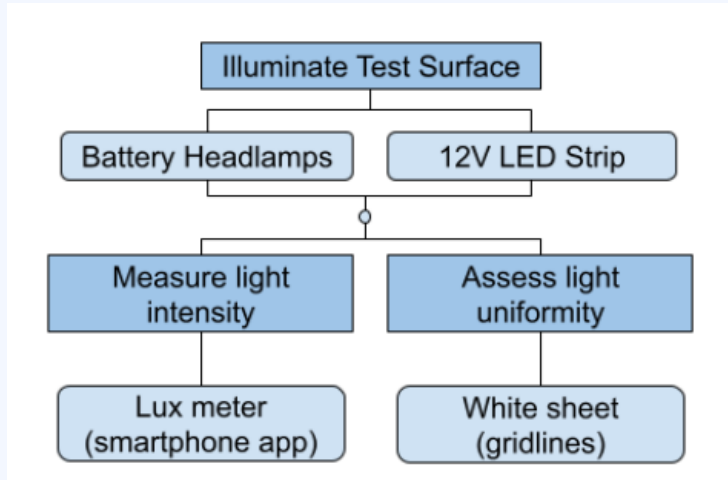

Functional criteria for lighting testing

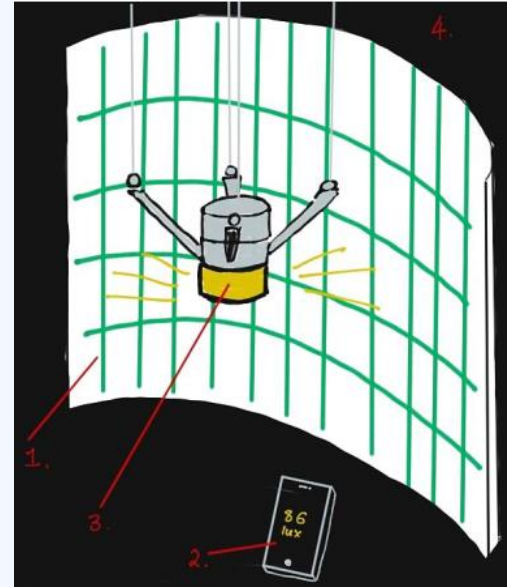

Schematic of testing setup used for lighting test

Functional Testing: Lighting – Results

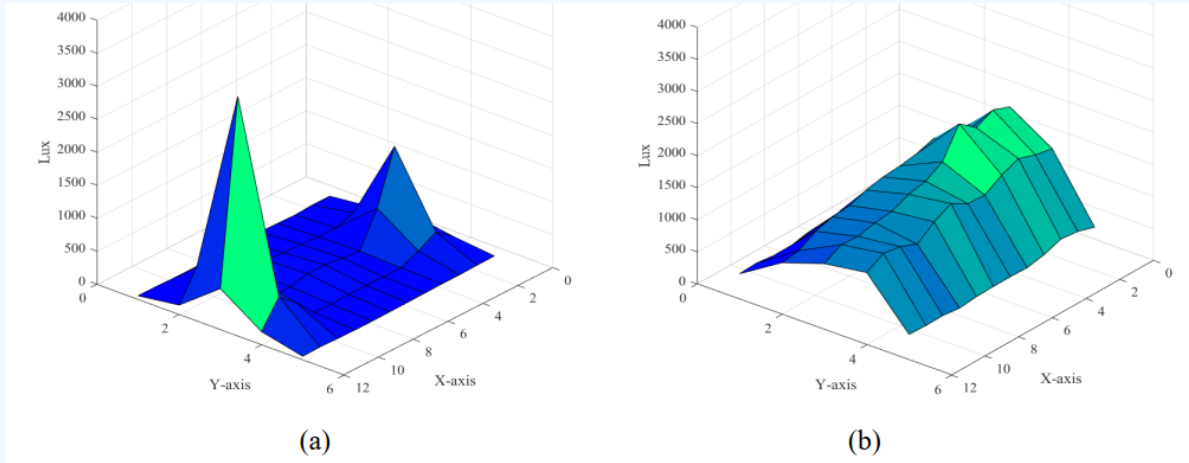

LIGHTING PERFORMANCE METRICS

Metric	Original Device	MARA Device
Average Lux	221.55	964.28
Lighting Uniformity Ratio	0.185	0.375
Max-to-Min Ratio	82.95	5.57

Field testing

Field Testing



Field Test – 19m Manhole



Field Test – 19m Manhole



Cover Frame Corrosion

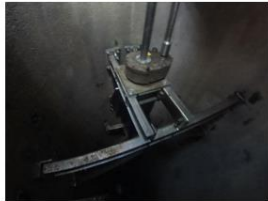

Penstock Operating Gearbox



Manhole Ladder

Corrosion on MH Cover frame

Ladder good (top section) First 30 rungs

Ladder poor (lower section) Corrosion and accumulation of rags/sludge observed

Walls fair (0-10 m)

Joint seal failure (10 m and 11 m) Active groundwater ingress observed

Walls poor (>10 m) Exposed aggregates and signs of progressive deterioration

Penstock poor condition Rusting and accumulation of rags/sludge observed

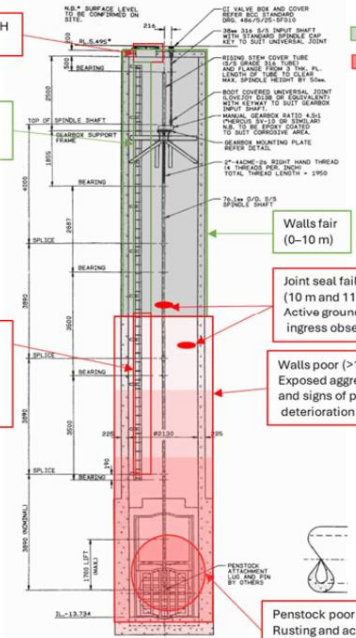

Good Condition
Poor Condition



Concrete Wall Leaking

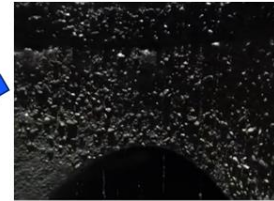

Eroded Manhole Wall



Sewer Door Penstock

Inspection Results Annotated Drawing



Reflection of Field Test and Future Improvements

Field test reflection:

- Improved spool chord

Future improvements:

- LiDAR and 3D Mapping
- Image stitching
- Dedicated mounting frame





For 75 years, SMEC has built a reputation as a trusted partner on major Transport, Water and Energy projects around the world.

SMEC is committed to positively impact the people, the environment and the clients and communities we serve. Through our network of global specialists, our specialist teams draw on deep expertise and systems thinking to simplify the complex and deliver integrated engineering solutions across a range of diverse environments.



James Shingles

Graduate Engineer - Water Infrastructure
james.shingles@smec.com
Brisbane, QLD, Australia

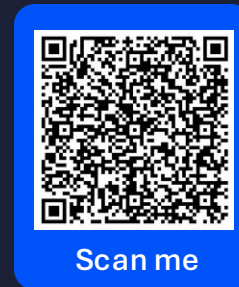

Slide Pack

Download this presentation